



SERIES AS200 ELASTOMERIC SPRAY

APPLICATIONS

SpecSeal® Elastomeric Spray is designed primarily for the protection of construction joints, curtainwall safing gaps, and certain through-penetrations.



PRODUCT DESCRIPTION

SpecSeal® Elastomeric Spray is a non-halogenated latex-based, highly elastomeric coating designed to provide passive smoke and fire protection in construction joints.

SpecSeal® Elastomeric Spray is engineered to adhere to virtually all construction surfaces and may be applied using airless spray equipment or with a brush (for small applications or touch ups).

SpecSeal® Elastomeric Spray dries to form a flexible shield against the propagation of fire. Its premium latex binder system is totally resistant to water and will not re-emulsify after drying. SpecSeal® Elastomeric Spray contains no inorganic fibers, asbestos, solvents.

FEATURES

- **Water-Based** for easy installation and cleanup
- **Non-halogenated.**
- **Thixotropic** for high-build application.
- **Auto Bonding.**
- **Safe...** no solvents! No asbestos!
- **Flexible!**
- **Water Resistant!**
- **Low Abrasion** for longer pump life and less maintenance.
- **UL Classified.**
- **Tested** with spray applied fire resistive materials (SFRM).
- **Paintable**

PERFORMANCE

When applied to a wet film thickness of 1/8" (3.2 mm) over appropriate backing materials, SpecSeal® Elastomeric Spray has been successfully tested in one, two, three and four hour joints. Consult factory for individual system designs and application requirements.

LIMITATIONS: Use product as per manufacturer's instructions. Use only in applications per the manufacturer's tested and published designs or specific recommendations. End user must ultimately determine the suitability of the product and designs to his specific requirement and assumes responsibility for its use. **PRODUCT CONTAINS WATER AND IS CONDUCTIVE UNTIL DRY. DO NOT APPLY IN THE PRESENCE OF EXPOSED OR ENERGIZED ELECTRICAL CONDUCTORS.**

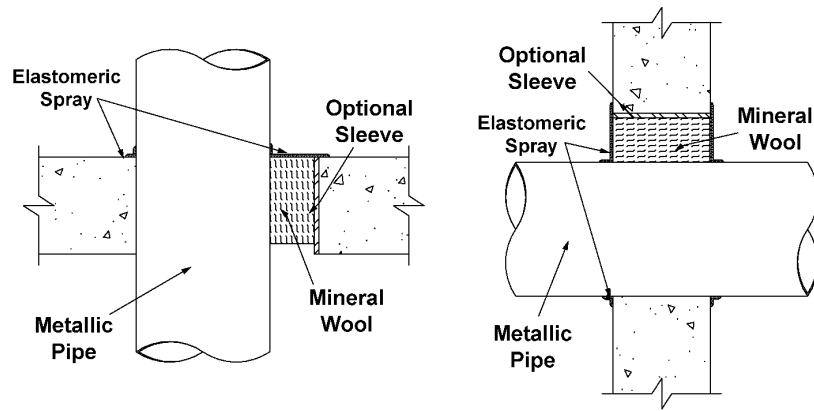
	CLASSIFIED FORMING MATERIALS FOR USE IN JOINT SYSTEMS SEE UL DIRECTORY OF PRODUCTS CERTIFIED FOR CANADA AND UL FIRE RESIS- TANCE DIRECTORY	
--	--	--

PHYSICAL PROPERTIES

PROPERTIES:	SERIES AS SPRAY		PROPERTIES:	SERIES AS SPRAY	
Color	Pale Blue and Red		Solvent Content	None	
Odor	Mild Latex		In-Service Temp.	≤120° F (49° C)	
Specific Gravity	1.1		Drying Time	Tack Free 2 Hours	
Solids	75%			Dry Through 24-48 Hours ^A	
Flame Spread	0*		STC Rating	61	
Smoke Developed	25*		VOC Content ^B	0.16 lb/gal (20.0 g/L)	
Movement	±33%**		Shelf Life	1 yr.	
Coverage	12.8 sq ft/gal @ 1/8" (0.31 sq m/L @ 3.2 mm)		* Tested to ASTM E84 (UL723) @ 14% coverage.		
Viscosity	110,000 cps		**500 Cycles per UL2079, AC30 (ICBO) and ASTM E1399		
pH	7.5		^A Dependent on temperature and humidity.		
			^B Per ASTM D3960 EPA Fed. Reference Method 24		

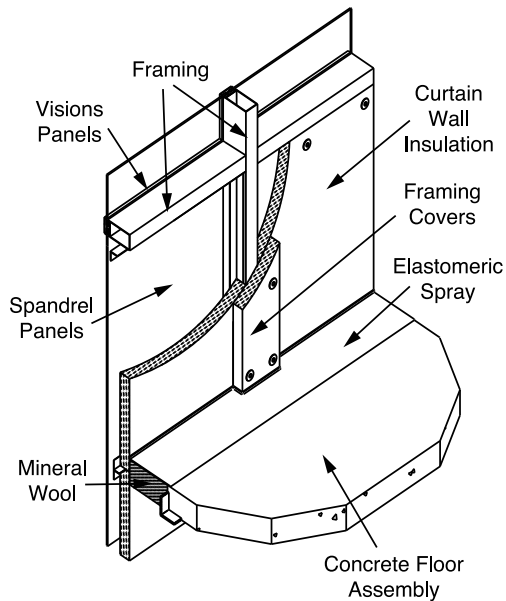


FIG. 1: METALLIC PIPE PENETRATIONS - CONCRETE/MASONRY FLOORS & WALLS



UL System No. C-AJ-1318
 F Rating – 2 Hr • T Rating – 0 Hr
 Steel or Iron Pipe: <12", Copper Pipe: <6"
 Annulus: Point Contact to 2"
 Forming Material: Nom 4 pcf mineral wool to 4" depth
 Spray Depth: 1/8" wet depth (+1/2" overlap)

FIG. 2: SLAB-EDGE SAFING GAP APPLICATIONS



UL System No. CW-S-2003
 Integrity Rating – 1-1/2 and 2 Hr
 Insulation Rating – 0 and 1/4 Hr
 Joint Width: Nom 8 in. wide.
 Forming Material: Nom 4 pcf mineral wool to 4-1/2" depth.
 Spray Depth: 1/8" wet depth (+1/2" lap onto adjoining substrates)

SPECIFICATIONS

The fire protective joint coating shall be a water-based, non-halogenated elastomeric coating and shall contain no solvents, inorganic fibers, nor asbestos. The coating shall dry to form a flexible, moisture resistant film and shall adhere to all common construction surfaces. The coating shall be thixotropic and shall be capable of being applied by brush or by airless spray. The approved coating shall be SpecSeal® Elastomeric Spray.

SPECIFIED DIVISIONS

- DIV. 7 07840 Through-Penetration Firestopping
- DIV. 13 13900 Special Construction Fire Suppression & Supervisory Systems
- DIV. 15 15250 Mechanical Insulation – Fire Protection
- DIV. 16 16050 Basic Electrical Materials & Methods

INSTALLATION INSTRUCTIONS

GENERAL: Areas to be protected must be clean and free of oil, loose dirt, rust or scale. Recommended storage temperatures range between 40°F (4°C) and 95°F (35°C). Installation temperature must be between 40°F (4°C) and 95°F (35°C). Recommended application temperature range is 60°F (16°C) to 90°F (32°C). When applying product at the lower end of the temperature range, warming the material to 70°F (21°C) will enhance drying characteristics. Drying time will vary according to prevailing temperature and humidity. Allow to thoroughly dry before exposure to moisture.

Consult appropriate manufacturer's drawing for system design requirements. Forming or packing materials are required as an integral part of various system designs.

Coating may be applied by airless spray in a single pass up to 3/16" (4.8mm) wet coating depth. If applying by brush or spraying on vertical surfaces where coating appears to be prone to slumping, multiple coats or the application of a thin tack coat may be required. DO NOT ATTEMPT TO THIN PRODUCT BY ADDING WATER. When dry, may be painted using most non-solvent based paints.

MAINTENANCE

Inspection: Installations should be inspected periodically for subsequent damage. Following safety precautions listed below (See Precautionary Information) and pertinent installation guidelines, remove coating in damaged areas down to undamaged material. Reapply fresh coating material to original coating thickness.

TECHNICAL SERVICE

Specified Technologies Inc. provides toll free technical support to assist in product selection and appropriate installation design. UL Systems, Material Safety Data Sheets and other technical information is available at the Technical Library at www.stifirestop.com.

PRECAUTIONARY INFORMATION

Consult Material Safety Data Sheet for additional information on the safe handling and disposal of this material. Wash areas of skin contact with soap and water. Avoid contact with eyes. The use of an OSHA or NIOSH approved mask for dust and mist environment is recommended. Apply in areas with adequate ventilation.

AVAILABILITY

SpecSeal® Elastomeric Spray is available from authorized distributors. Consult factory for the names and locations of the nearest sales representatives or distributors. ■■■■■

TABLE A: APPLICATION EQUIPMENT

NOTICE: Spray application of SpecSeal Elastomeric Spray requires airless spray equipment meeting the following specifications:

Working Pressure: Min. 2500 PSI

Delivery: Min. 1.0 U.S. gpm (2.1 l/min.) recommended

Spray Tip Orifice: 0.023" to 0.026" (0.58 to 0.66 mm) recommended

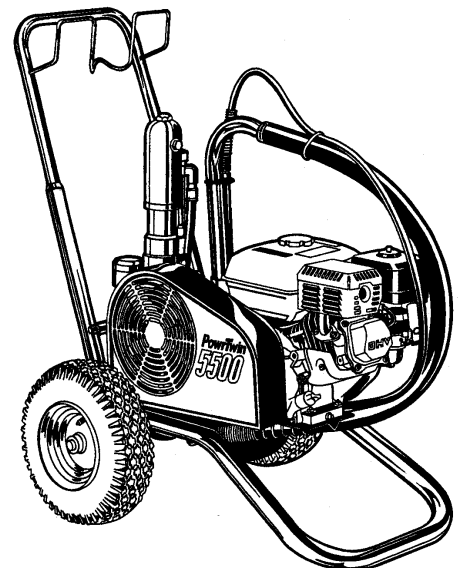
Wetted Parts All seals and contact surfaces suitable for contact with latex emulsions.

A minimum 3/8" (9.5 mm) fluid line is required, a 1/2" (13 mm) line is preferred. Consult pump manufacturer for long hose runs or lifts to higher elevations. A reversible spray tip is recommended. A 6" (152 mm) fan pattern is suggested to minimize overspray.

The following airless spray equipment has demonstrated suitability for application of this product. STI makes no warranties concerning the suitability or use of this equipment and has no affiliation of any kind with its manufacturer.

The following equipment is manufactured by Titan Tool, Inc. Franklin Lakes, NJ:

Item	Item Name & Description
PowrTwin Model 3500 Sprayer	Electric or gas powered airless sprayer



ORDERING INFORMATION

SpecSeal® Elastomeric Spray
is available in 5 gal. pails, 55 gal. drums
are available on a special order basis.

AS205 5 gal. Pail 1,155 cu. in. (19 liters)



CITY OF NEW YORK MEA 310-99-M

Additional SpecSeal Products...

ES Series Sealant

Inexpensive water-based Elastomeric Sealant for construction joint applications. Design to provide up to $\pm 33\%$ movement.

SSS Series Sealant

The industry's most versatile sealant provides the firestopping solutions for a wide range of combustible and noncombustible applications. Water-based intumescent sealant expands up to 8X!

SSP Firestop Putty

Available both in bar form and in pads, putty provides easy retrofit for through-penetrations and economical protection for electrical boxes.

Firestop Mortar

Lightweight, versatile and economical! The best choice for large or complex installations.

Pensil® Silicones

Sealants and foam for through-penetrations and construction joints. Unexcelled aging characteristics and flexibility.

Intumescent Wrap Strips

Three grades of intumescent wrap strips provide an unmatched combination of flexibility, economy, and expansion (up to 30X). Systems for plastic pipes including FR Polypropylene up to 8" trade size!

Molded Firestop Collars

Easy to install, economical protection for ABS and PVC pipes (both solid and foam core) as well as CPVC, PVDF, and FRPP. Collars available up to 6" trade size.

Important Notice: All statements, technical information, and recommendations contained herein are based upon testing believed to be reliable, but the accuracy and completeness thereof is not guaranteed.

WARRANTY: Specified Technologies Inc. manufactures its goods in a manner to be free of defects. Should any defect occur in its goods (within one year), Specified Technologies Inc., upon prompt notification, will at its option, exchange or repair the goods or refund the purchase price.

Limitations and Exclusions: THIS WARRANTY IS IN LIEU OF ALL OTHER REPRESENTATIONS EXPRESSED OR IMPLIED (INCLUDING THE IMPLIED WARRANTIES OF MERCHANTABILITY OR FITNESS FOR USE) AND UNDER NO CIRCUMSTANCES SHALL SPECIFIED TECHNOLOGIES INC. BE RESPONSIBLE FOR ANY INCIDENTAL OR CONSEQUENTIAL PROPERTY DAMAGE OR LOSSES. PRIOR TO USE, THE USER SHALL DETERMINE THE SUITABILITY OF THE PRODUCT FOR ITS INTENDED USE, AND THE USER ASSUMES ALL RISKS AND LIABILITY FOR SUBSEQUENT USE.

No statement or recommendation not contained herein shall have any force or effect unless in an agreement signed by officers of seller and manufacturer.

MADE IN THE USA – COPYRIGHT © 2007 SPECIFIED TECHNOLOGIES, INC.



Specified Technologies, Inc.

Specified Technologies Inc. • 200 Evans Way, Somerville NJ 08876 • Phone: 800.992.1180 • Fax: 908.526.9623

